

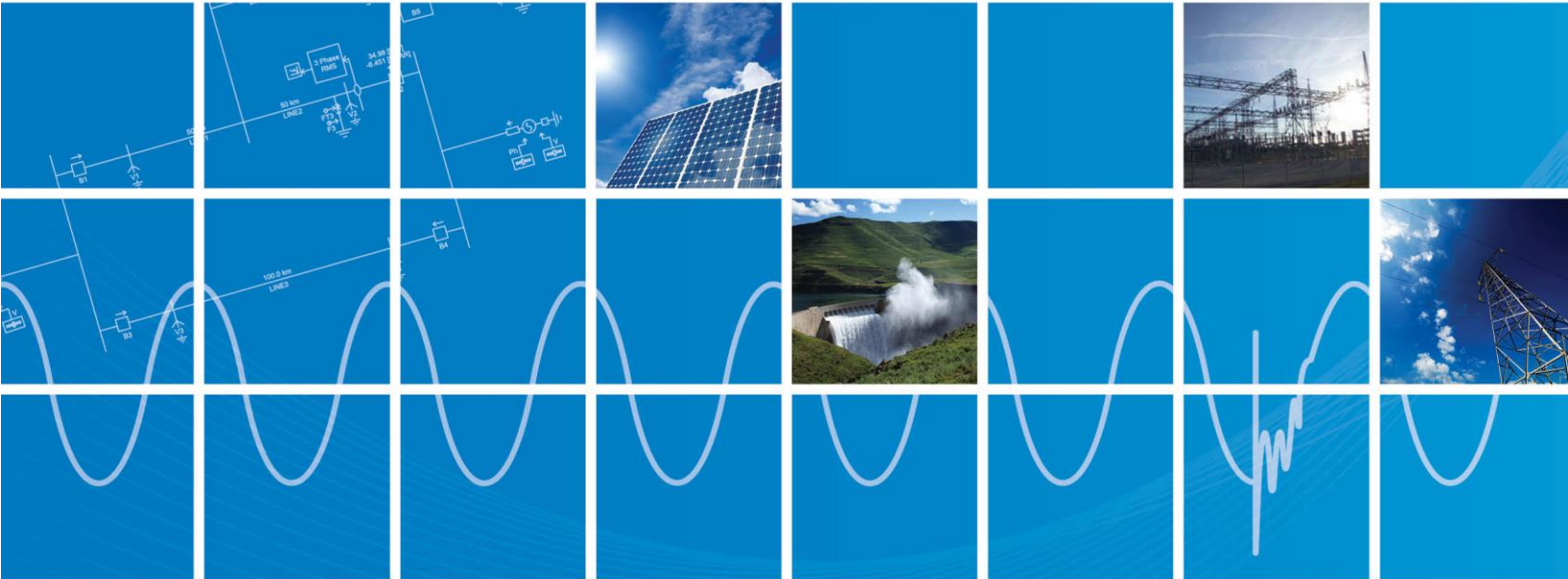

# Three-Phase Battery Energy Storage System

Written for PSCAD v4.6 and later

May 14, 2019  
Revision 3



## 1.0 How to set up the Simulation

Load the library (Battery\_Model\_v2.pslx) and simulation case (Non\_Swtch\_Battery3PhMarch2018.pscx) into PSCAD. The library is already linked with the .lib file as shown in Figure 1. There is no need to link the object files for 4.6 version or better.

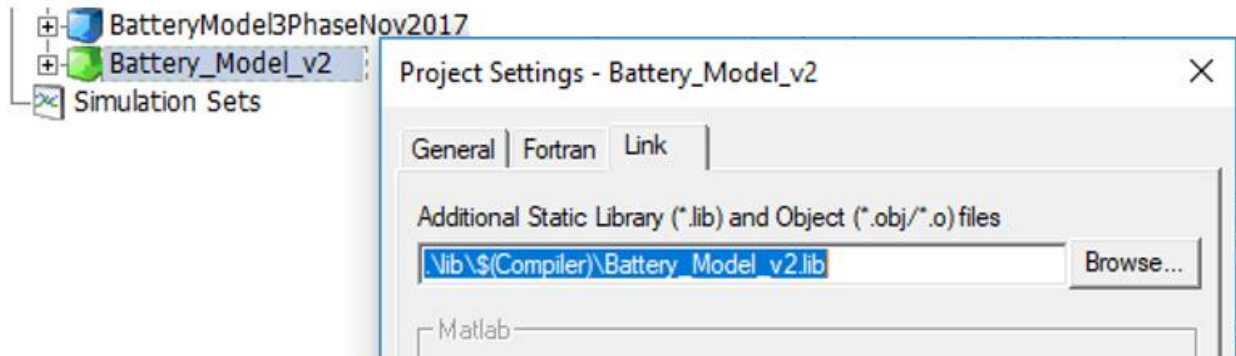



Figure 1: Simulation case and the library file linked with the object fields in the Lib folder

In each folder, there is one .lib file, which is compatible with associated compiler.

For example:

The .lib file in “ if15 ” is compatible with Intel-Fortran Version 15 compiler

Or

The .lib file in “ gf42 ” is compatible with GFortran version 4.2 compiler

In addition, the “Project Tree” shown in Figure 2 displays the sub-modules in the simulation. Click on the modules to navigate between them. For example to see the graphs and to controls click on the “Graphs\_and\_Controls” module or double click on the module shown as follows (it can be found in the main canvas).

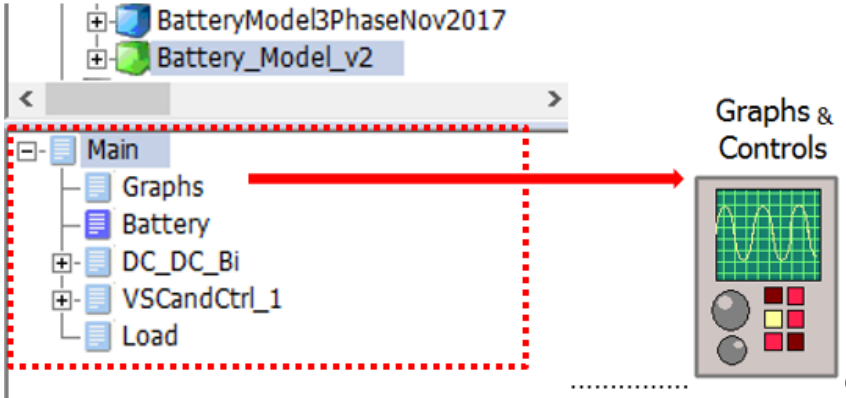

Figure 2: Use Project Tree to see the submodules and navigate easily through them

In addition, the signals in the canvas can be traced using “virtual wires” option shown in Figure 3 . The simulation must be compiled to activate “virtual wires”.

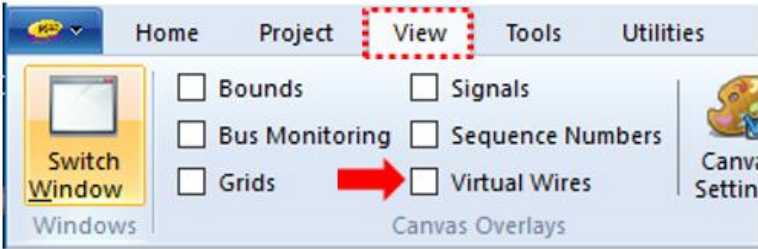

Figure 3: Use Virtual Wires to observe the signals in the canvas

## 2.0 General Description of the Battery System

Figure 4 shows a three-phase battery energy storage system (BESS) comprising of Buck/Boost DC-DC converter and voltage source converter (VSC). A general description of each module is given to explain how the system works and what functionality can be expected from this system.

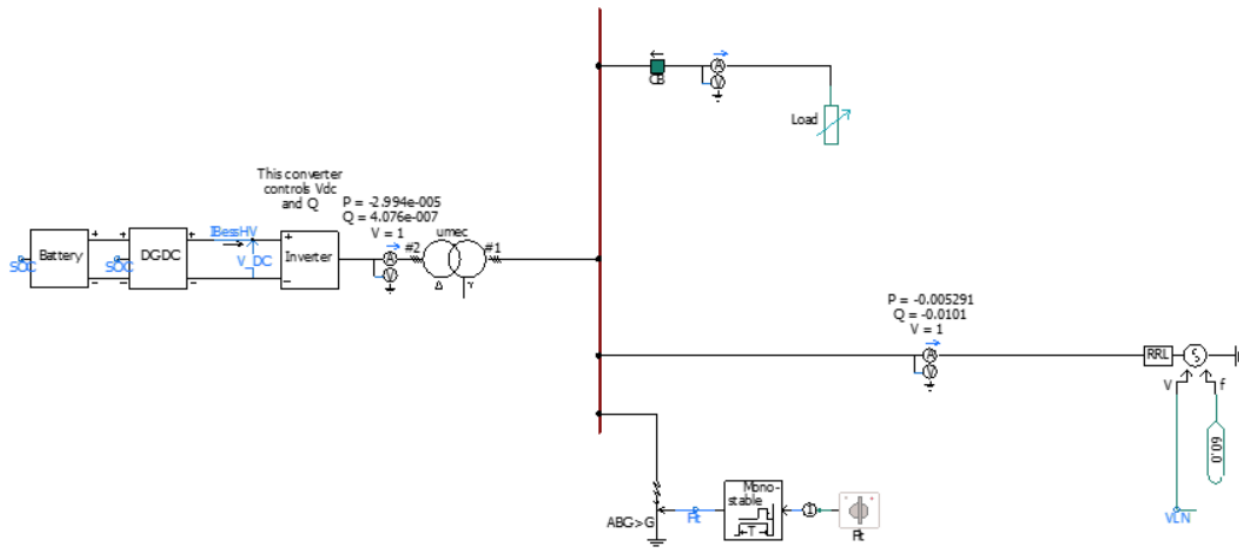

Figure 4: Grid-tied battery energy storage system (BESS)

The battery is connected to a DC-DC converter (Buck/Boost converter). The DC-DC converter operates in Buck or Boost mode to charge or discharge the Battery. The DC-DC converter connects to the grid-tie converter via a DC Link system. The grid-tie converter controls the DC voltage ( $V_{DC}$ ) on the DC Link and reactive power ( $Q$ ).

## 2.1 Battery

Figure 5 shows the Lithium battery model and its parameters. The DC voltage rating for the battery is 500V. This model is based on a few simplifying assumptions and has some limitations [1].

Assumptions:

- During the charge and discharge cycles, the internal resistance is assumed to be constant.
- The amplitude of the current does not have any effect on the internal resistance
- The discharge characteristics curve of the battery is used to derive the battery parameters, since the discharge and charge characteristics are assumed to be the same.
- The amplitude of the current does not have any effect on the capacity of the battery (No Peukert effect).
- Temperature does not change the model's behavior.
- Self-discharge of the battery is not represented.
- Charge and discharge history does not affect battery characteristics (i.e. No hysteresis)

Limitations:

- The battery voltage cannot be negative and the maximum battery voltage is not limited.
- The capacity of the battery cannot be negative and the maximum capacity is not limited.

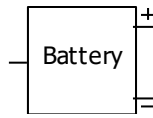

(a)

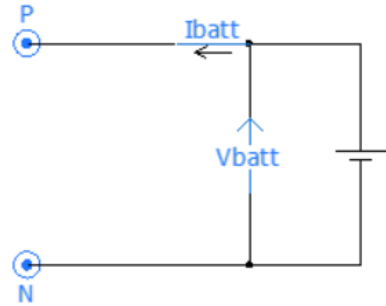

(b)

[Battery\_Model\_v2:battery] id='1822777648'

Configuration

**General**

Battery name	Bat1
Data entry	Shepherd model
Nominal voltage	0.5 [kV]
Rated capacity	0.0167 [kA*hr]
Loss of capacity at nominal cur	20
Initial state of charge	90

**Outputs**

State of Charge [%]	SOC
---------------------	-----

(c)

[Battery\_Model\_v2:battery] id='1748810377'

Shepherd Model

**General**

Nominal Capacity	0.95 [pu]
Resistive Drop	0.001 [pu]
Voltage at Exponential Point	1.03 [pu]
Capacity at Exponential Point	0.4 [pu]
Fully Charged Voltage	1.15 [pu]

(d)

Figure 5: Lithium battery model and parameters

### 3.0 Buck/Boost converter

The Buck/Boost converter is shown in Figure 6. It is connected to the battery (Low voltage, VL: 500V) on the left side and connects to DC link system on the right side (High voltage, VH: 1kV).

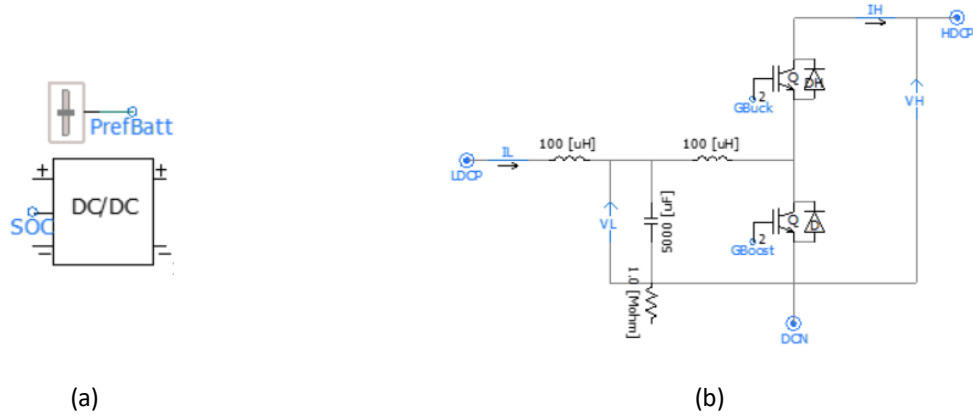

(c) Input parameters for the DC/DC converter module:

Parameters	
<b>General</b>	
Converter On/Off [On:1; Off:0]	DBlk
Rated Power [MW]	1.0
Power set-point [MW]	PrefBatt

Figure 6: (a) Buck/Boost converter module (b) power electronic circuit (c) input parameters

### 3.1 Upper level control system and ratings

The upper level control system is shown in Figure 7. This control system is manual and also accessible in the “Graphs\_and\_Controls” module.

The control panel “Charger On/Off” is to enable/disable the Buck/Boost converter manually. This controller can also be provided automatically based on an over-voltage or an over-current protection system.

The other controller, “Mode” controls the mode of operation for the converter therefore the battery can be charged or discharged. This controller is also manual. However, it can be programmed automatically based on a power management system.

The SOCpermit is a signal that does not permit charging or discharging when SOC is above 100% or less than 5% respectively.

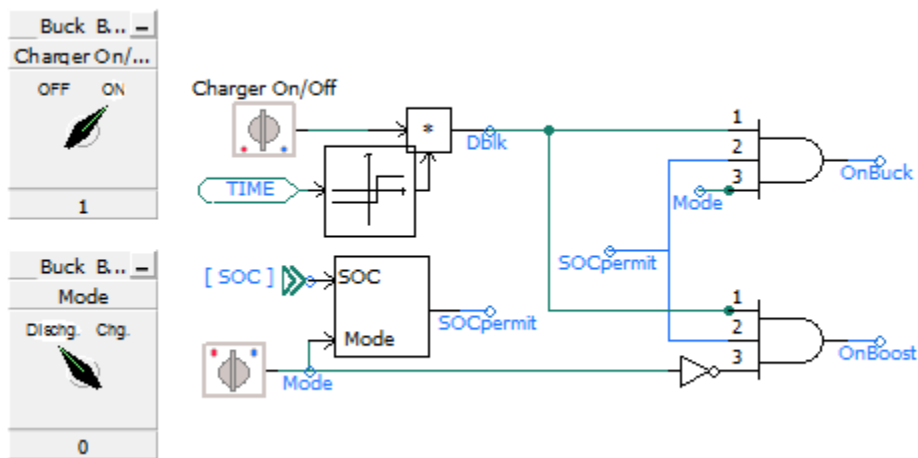

Figure 7: Upper level controllers

The reference power can be varied for the converter using the slider shown in Figure 8. This value is selected based on the ratings of the battery. In this example it is 300kW.

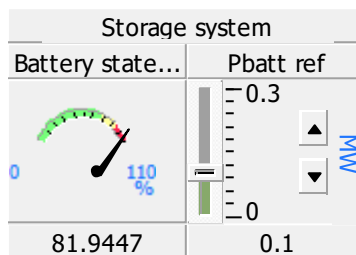

Figure 8: Variable input power using slider in the Graphs\_and\_Controls module



### 3.2 Lower level controllers

When the converter operates at dis-charging mode, the Boost converter is enabled (see Figure 7). The Boost controller is shown in Figure 9 where the reference power is compared against the low voltage side power (battery power,  $P_{batt\_pu}$ ). The PI controller with  $K_{pBoost}$  and  $T_{iBoost}$  coefficients and its limit for duty cycle ( $D_{limBst}$ ) is shown in Figure 10.

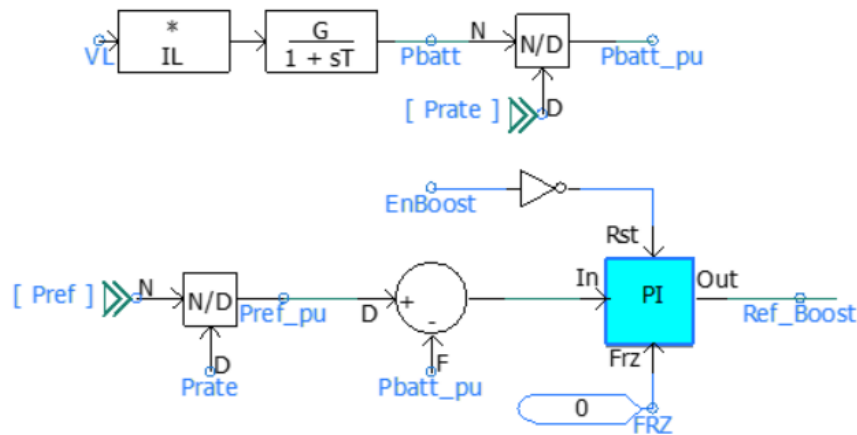

Figure 9: The power controller for boost converter

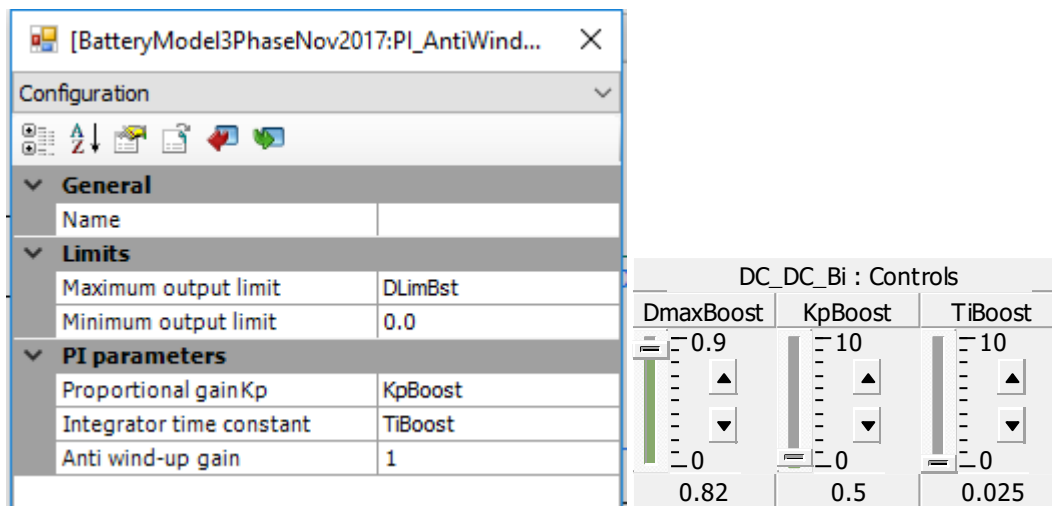
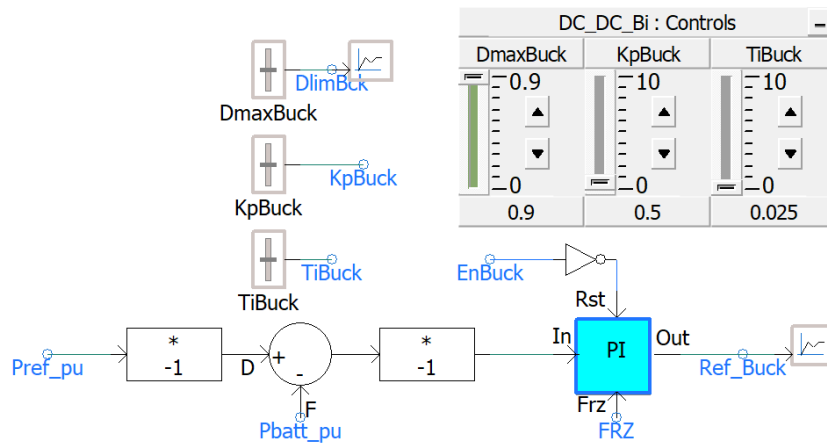

Figure 10: The parameters of the PI controller for boost converter

When the converter operates at charging mode, the Buck converter is enabled (see Figure 7). The Buck controller is shown in Figure 11 where the reference voltage is compared against battery power,  $P_{batt\_pu}$ . The PI controller with  $K_{pBuck}$  and  $T_{iBuck}$  coefficients and its limit for duty cycle ( $D_{limBck}$ ) is shown as well.



DC\_DC\_Bi : Controls

DmaxBuck	KpBuck	TiBuck
0.9	10	10
0	0	0
0.9	0.5	0.025

[BatteryModel3PhaseNov2017:PI\_AntiWind...]

Configuration

General

Parameter	Value
Name	
Maximum output limit	DLimBck
Minimum output limit	0.0
Proportional gain Kp	KpBuck
Integrator time constant	TiBuck
Anti wind-up gain	1

Figure 11: The power controller for Buck converter

## 4.0 Three-phase grid-tie converter

The three-phase inverter controls the DC voltage ( $V_{DC}$ ) and the reactive power. To edit the parameters of the converter, right click on the component and select “Edit parameters”.

### 4.1 Input Parameters of converter and controls

Figure 12 shows the ratings of the converter such as rated MVA (0.35 MVA), rated AC voltage (0.69 kV) and AC system frequency (60 Hz).

Note: the parameters has a symbol and a unit. For example the rated AC voltage is in kV and it is line-to-line RMS voltage and in the module it is introduced by symbol “VLL”.

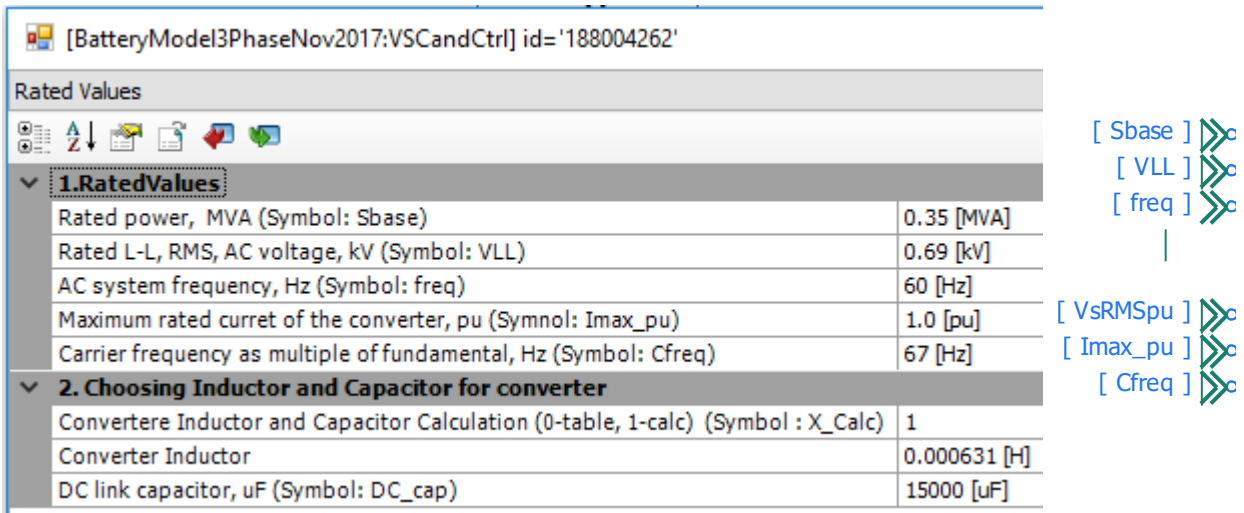

(a)

(b)

Figure 12: (a) Rated values window showing the ratings of the converter and (b) associated symbol names for the parameters

The rated inductor and capacitor for the converter can be chosen from the input table if  $X_{cal}$  is selected as zero or they can be calculated if  $X_{cal}$  is one, as shown in Figure 13.

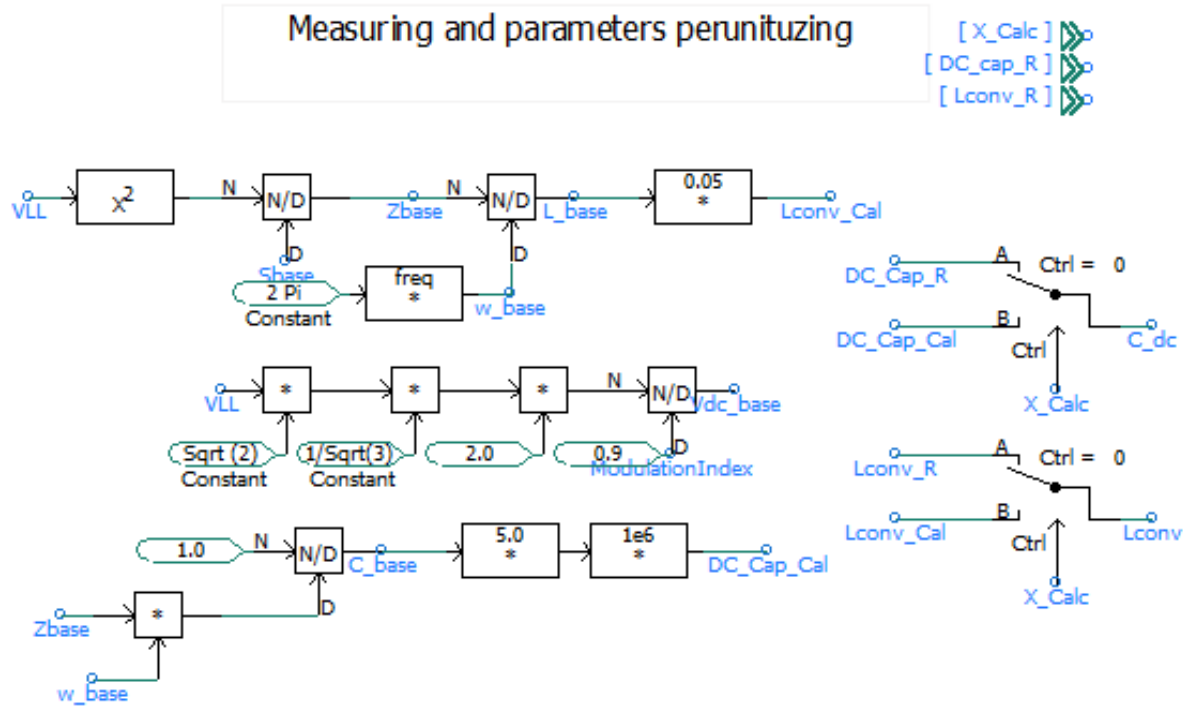

Figure 13: Computation of rated inductor and capacitor values, if  $X_{cal}$  is zero the values in the input table are selected. If  $X_{cal}$  is one the values are calculated

Control Setting Window shown in Figure 14 provides the options to control the DC voltage or active power if  $V_{dc\_P\_ctrl1}$  is chosen as zero or one. In addition, it provides the options to control the reactive power or AC voltage if  $Q\_Vac\_ctrl1$  is chosen as zero or one.

Control Settings	
d axis control mode (0: Vdc control; 1: P control) (Symbol:dmode)	Vdc_P_ctrl1
q axis control mode (0: Q control 1: Vac control) (Symbol:qmode)	Q_Vac_ctrl1
d or q axis priority: 0-Iq, 1-Id (Symbol:IlimPriority)	Iq_Id_ctrl1
Converter De-block signal (0 : block, 1: de-block) (Symbol:DBlk)	DbkVSC

0 Vdc\_P\_ctrl  
0 Q\_Vac\_ctrl  
1 Iq\_Id\_ctrl1

This converter controls Vdc and Q

Figure 14: Control setting for the convertor, active power or DC voltage and reactive power or AC voltage can be controlled by choosing zero or one

The command orders and the PI coefficient values for the controllers are shown in the Figure 15.

Control Parameters	
<b>1. Control Orders</b>	
AC voltage order, pu (Symbol: Vac_ord_pu)	Vac_ord_pu
Active power order, MW (Symbol: Pref)	P_ord_MW
DC voltage order, kV (Symbol:Edc_ord)	Edc_ord_kV
Reactive power ordered, Mvar (Symbol: Q_ord)	Q_ord_MVAR
<b>2. d-axis control (Real power axis)</b>	
d regulator proportional gain (Symbol: Kpd)	Kpd
d regulator integrator gain (Symbol:Tid)	Tid
<b>3. q-axis control (Reactive power axis)</b>	
q regulator proportional gain (Symbol:Kpq)	Kpq
q regulator integrator gain (Symbol:Tiq)	Tiq
<b>4. DC voltage control</b>	
Edc regulator proportional gain (Symbol:kp_Edc)	Kp_Edc
Edc regulator integrator gain (Symbol:Ti_Edc)	Ti_Edc
<b>5. Active Power control</b>	
Active power regulator proportional gain (Symbol:Kp_P_M)	Kp_P_M
Active power regulator integrator gain (Symbol:Ti_P_M)	Ti_P_M
<b>6. Reactive power control</b>	
Active power regulator gain (Symbol:Kp_Q)	Kp_Q
Q regulator time constant (Symbol: Ti_Q)	Ti_Q
Q max	0.6 [pu]
<b>7. AC voltage control</b>	
Measured AC voltage	Vrms_BESS_pu
Vac regulator proportional gain (Symbol:Kp_Vac)	Kp_Vac
Vac regulator integral gain (Symbol:Ti_Vac)	Ti_Vac
Vac max pu (Symbol:Vac_max_pu)	1.1 [pu]
Vac min pu (Symbol:Vac_min_pu)	0.9 [pu]
<b>8. PLL</b>	
PLL regulator gain (Symbol:Kp_PLL)	Kp_PLL
PLL regulator integrator gain (Symbol:Ki_PLL)	Ki_PLL

Figure 15: Control parameters of the converter

Figure 16 shows the order signals for DC voltage controller and reactive power controllers of the VSC converter.

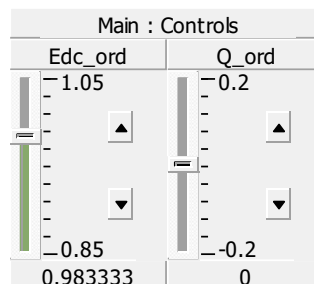

Figure 16: Variable order signals for VSC converter – find the slider in the Graphs\_and\_Controls module

Figure 17 shows the coefficients for PI controllers and the panels to modify the values if required.

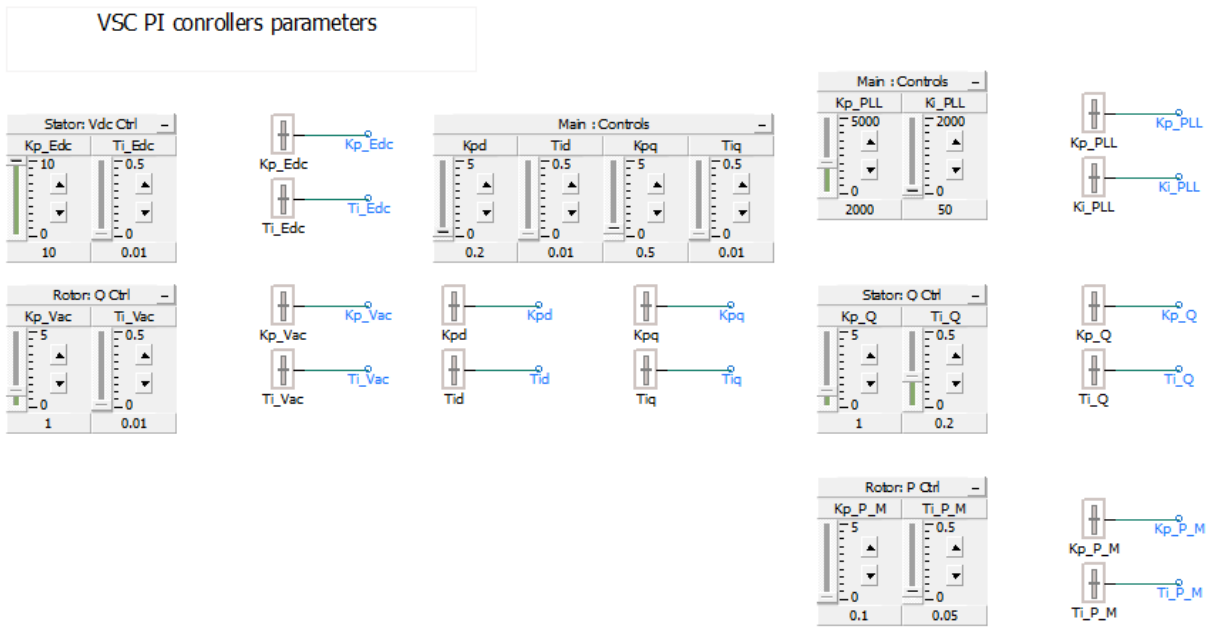

Figure 17: The Kp and Ti coefficients of the PI controllers of converter's controllers

## 4.2 Non-switching power electronic circuit of the converter and its controls

Controls module and simplified converter circuit are shown in Figure 18.

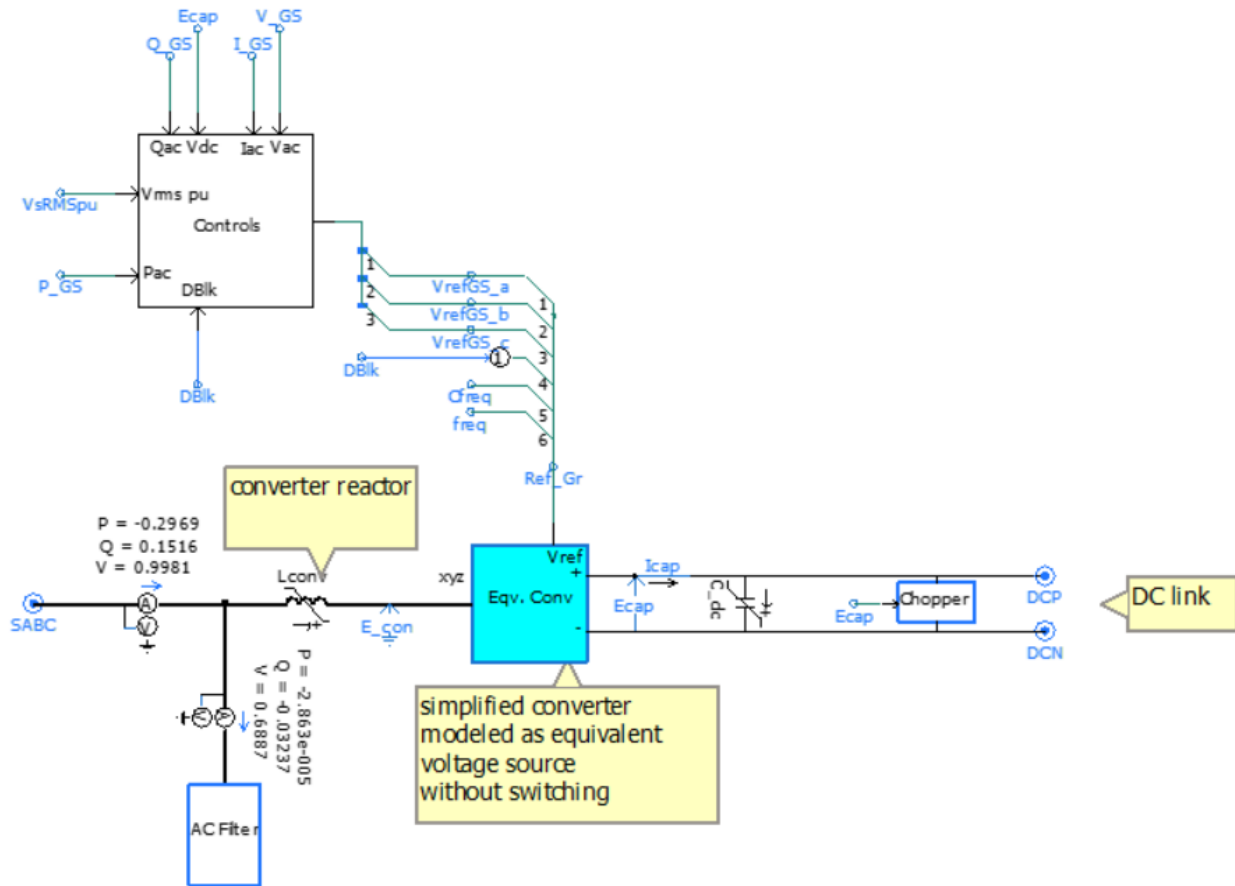

Figure 18: Overall circuitry for the converter and controls

### 4.3 Controller

The controls, shown in Figure 19, regulates the DC bus voltage ( $E_{cap}$ ) and reactive power ( $Q$ ). The reference for the reactive power control is set to zero. The control parameters are given in Figure 20. Most of these parameters are also described in Figure 12, Figure 14, Figure 15, Figure 16, and Figure 17.

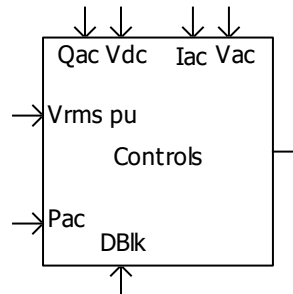

Figure 19: Control component

Configuration	
<b>1. Control modes</b>	
d axis control mode (0: Vdc control; 1: P control )	dmode
q axis control mode (0: Q control 1: Vac control)	qmode
d or q axis priority: 0-Iq, 1-Id	ILimPriority
<b>2. General</b>	
AC voltage order (Vac_ord, pu)	Vac_ord_pu
DC voltage order (Edc_ord,kV)	Edc_ord
Active power order	Pref
Reactive power ordered (Qord, Mvar)	Q_ord
Rated MVA	Sbase
AC system frequency	freq
Rated AC voltage	VLL
Vdc_base	Vdc_base
VSC inductance	Lconv
Mid-Reject Filter (0-not, 1-yes)	Filter_Calc
Maximum per unit curret	Imax_pu
Third harmonic component coefficient [pu]	0.15



PI controller parameters	
<b>1. Decoupled controller d-axis</b>	
d regulator gain	Kpd
d regulator time constant	Tid
<b>2. Decoupled controller q-axis</b>	
q regulator gain	Kpq
q regulator time constant	Tiq
<b>3. PLL</b>	
PLL regulator proportional gain	Kp_PLL
PLL regulator integral gain	Ki_PLL
<b>4. DC voltage control</b>	
Edc regulator gain	Kp_Edc
Edc regulator time constant	Ti_Edc
<b>5. Active power control</b>	
P regulator gain	kp_P_M
P time constant	Ti_P_M
<b>6. AC voltage control</b>	
Vac regulator gain	Kp_Vac
Vac regulator time constant	Ti_Vac
Vac max pu	Vac_max_pu
Vac min pu	Vac_min_pu
<b>7. Reactive power control</b>	
Q regulator gain	Kp_Q
Q regulator time constant	Ti_Q
Maximum reactive power (+/-)	Qmax

Figure 20: control parameters

The per-unitizing and transformation of current and voltage measurements are shown in Figure 21, Figure 22 and Figure 23 respectively. The rated power ( $S_{base}$ ) and rated voltage ( $V_{acbase}$ ) are used to per-unitized the measured quantities and calculate the maximum current.

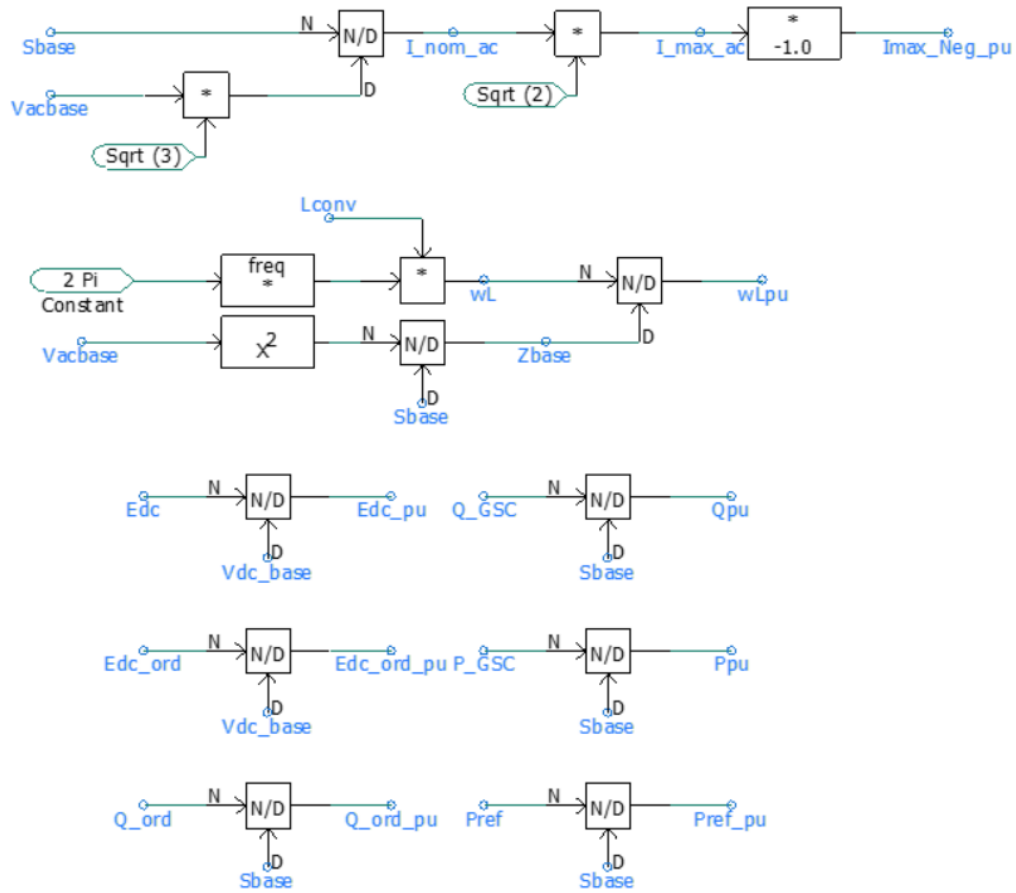

Figure 21: per-unitization of the measured parameters

Low pass filters with characteristic frequency of 600 Hz were added to improve the quality of dq quantities by filtering out some of the high frequency harmonics of the power electronic converter.

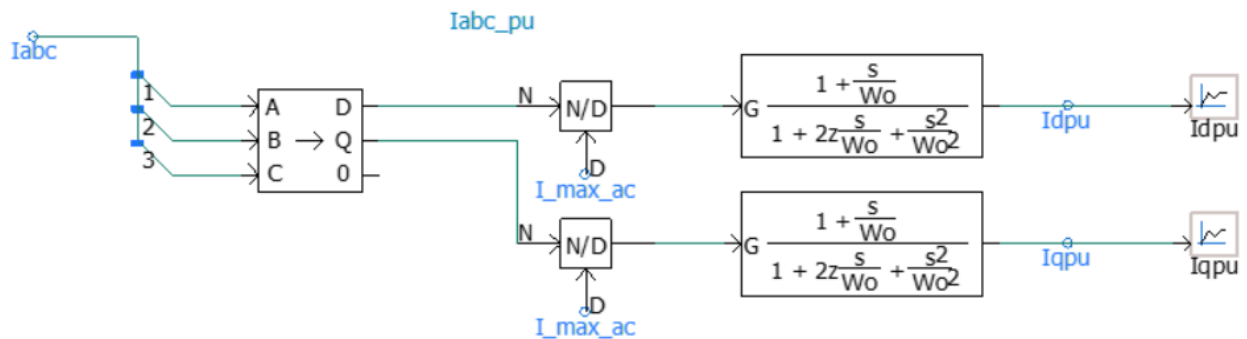

Figure 22: Current per-unitizing, transformation from abc to dq0 and filtering

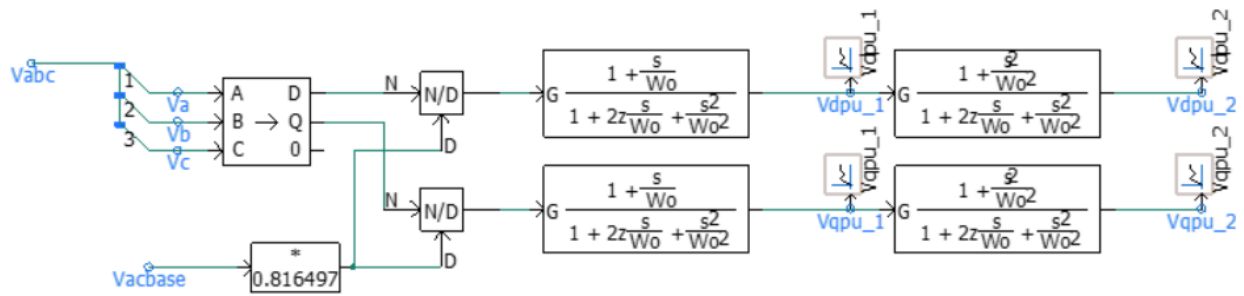

Figure 23: Voltage per-unitizing and transformation from abc to dq0 and filtering

The DC bus voltage and reactive power controls are shown in Figure 24. These controllers are selected by the command signals  $d_{mode}$  and  $q_{mode}$  respectively (see Figure 14). These controllers generate the d-axis and the q-axis current orders (i.e.  $I_{d\_ord\_pu}$  and  $I_{q\_ord\_pu}$ ) for the decoupled control respectively. Normally this converter is operated such that no reactive power is transmitted to or absorbed from the AC system ( $Q_{ref} = 0.0$ ) at nominal voltage.

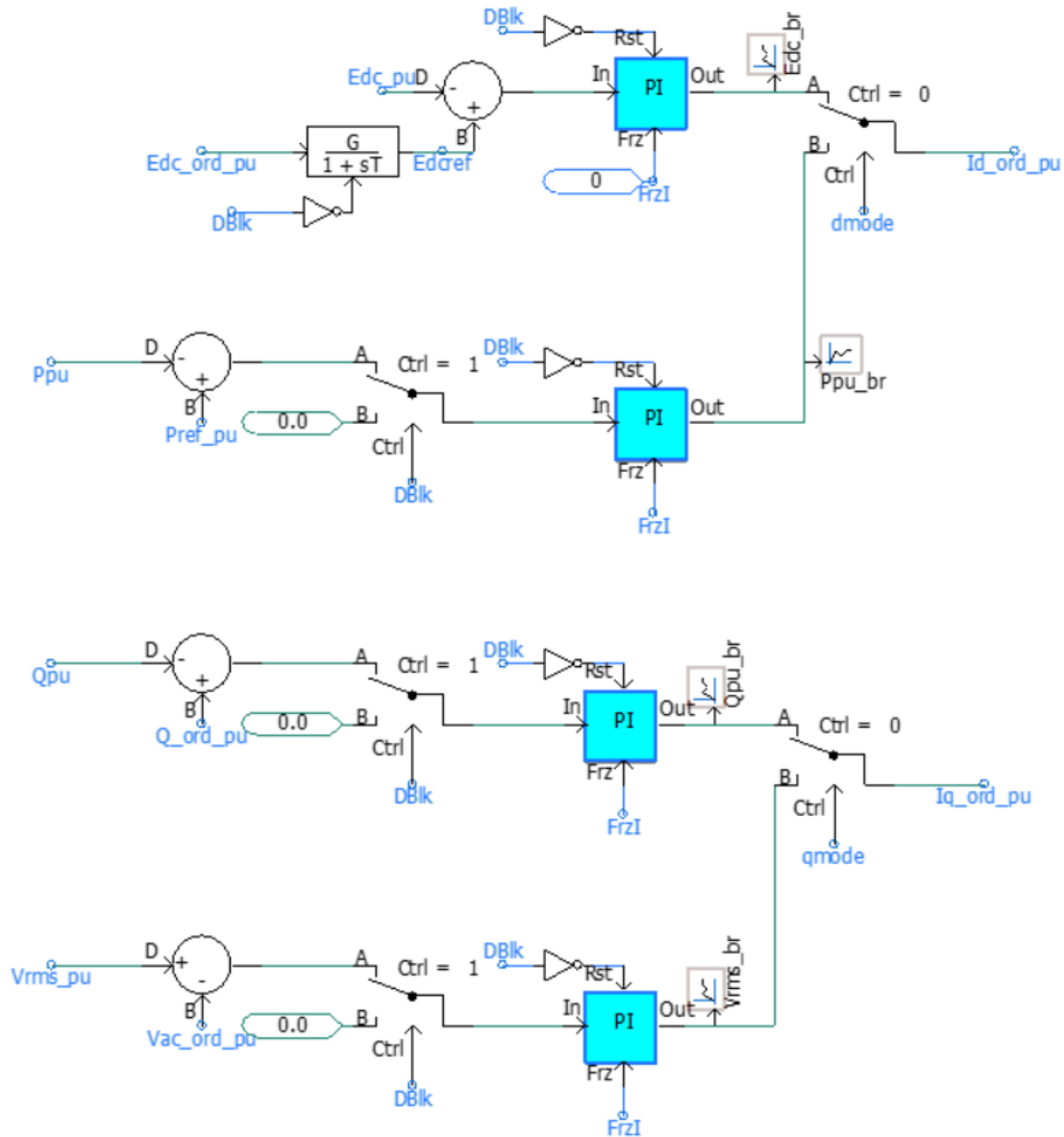

Figure 24: The DC voltage and reactive power controllers are chosen by the dmode and qmode command signals

The current of the converter is limited by PI controller's limits. For this converter, the default limiting function is chosen to give priority to the d-axis as shown in Figure 25 (priority signal is set to 1 see Figure 14). If the priority is given to the q-axis (Q control), the priority signal should be set to 0.

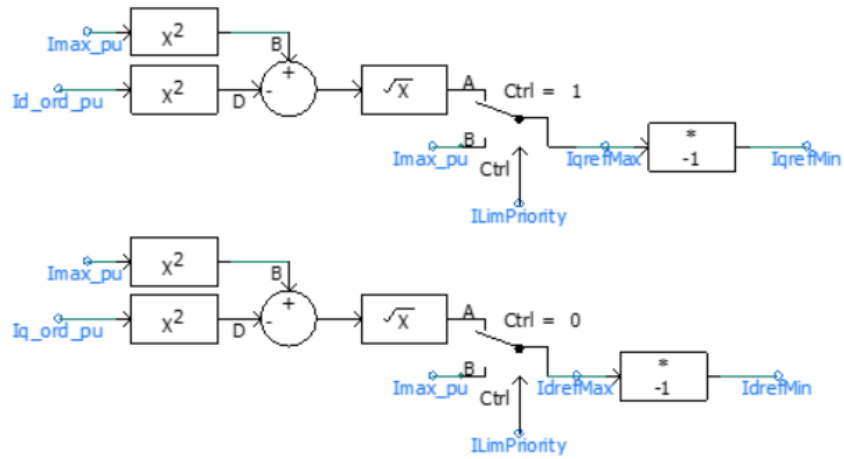

Figure 25: calculation of d- and q-frames current limits.

The decoupled current controls shown in Figure 26 are used to generate the converter reference voltages i.e.  $v_{d1\_ref}$  and  $v_{q1\_ref}$ . In order to decouple (i.e. reduce their effect on each other) the terms  $I_{q\_pu\_Gsc} * w_{Lpu}$  and  $I_{d\_pu\_Gsc} * w_{Lpu}$  are subtracted and added to d-frame and q-frame respectively.

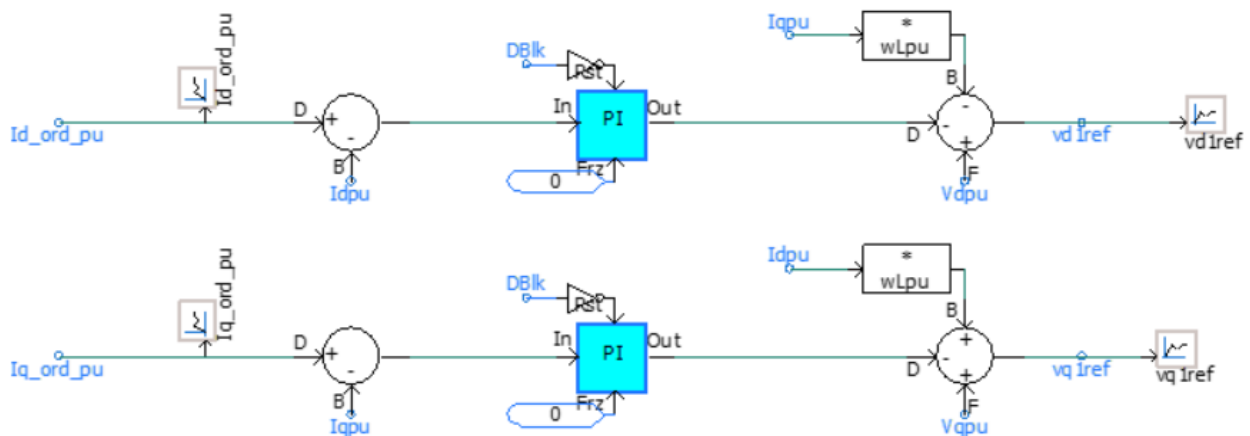

Figure 26: d- and q-frames decoupled current controllers.

As shown in Figure 27, the reference voltages i.e.  $v_{d1\_ref}$  and  $v_{q1\_ref}$  are converted from rectangular to polar domain (MagntLAngle). The magnitude (Magnt) multiplied by the peak phase voltage and then divided by half of the DC voltage to make sure that the magnitude of the reference voltage is limited so that the converter can create it at its output. The magnitude (Mag) is per-unitized and limited to 1.15 pu. The three-phase reference voltage waveforms are obtained by applying the dq0 to abc transform to  $v_{d1\_ref}$  and  $v_{q1\_ref}$ , using thetaPLL as the conversion angle. Up to this point, the reference wave-shapes are calculated in per-unit using the AC voltage peak to ground as the base voltage. The third harmonic is added to enhance the modulation index.

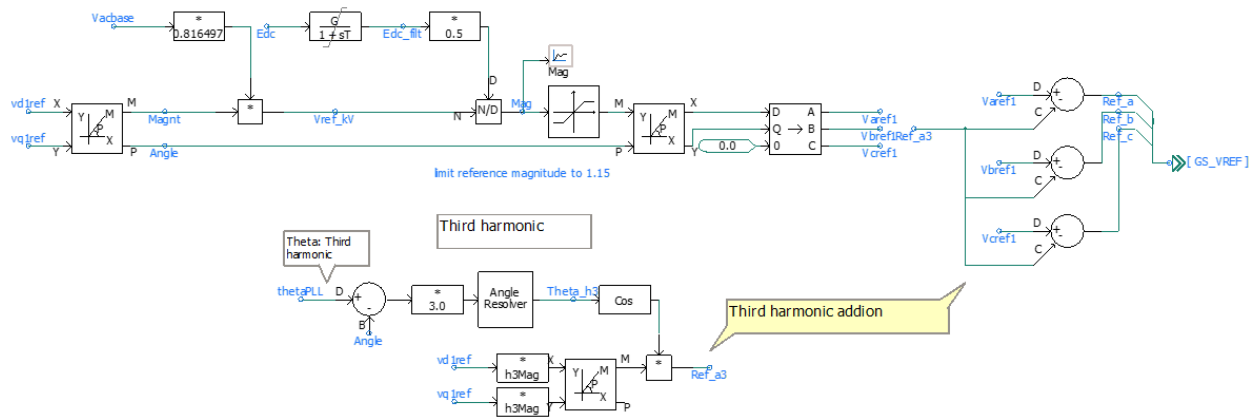

Figure 27: Reference voltages with third harmonic injection provided by controller

## 5.0 Simulation Results

### 5.1 Simulation results for discharging mode:

The dynamic of the system for discharging mode is shown in Figure 28 when the reference power is changed from 100 to 200kW and from 200 to 300kW. The battery is at 90 percent state of charge (SOC) at the beginning. If the State of charge (SOC) reduces to 5 % when the SOCprmit block the controllers and shut down the converter.

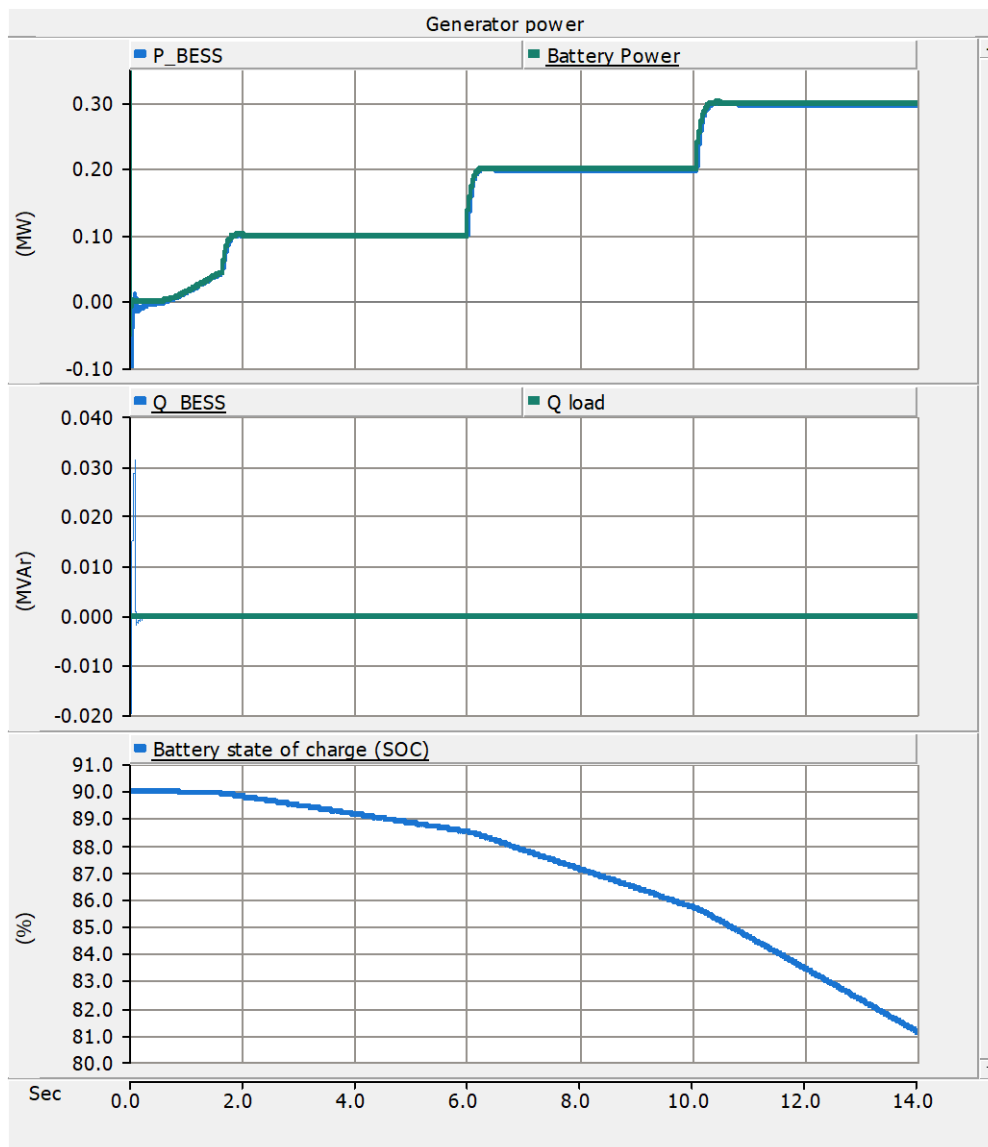

Figure 28: Simulation results of discharging operation mode

## 5.2 Simulation results for charging mode

The dynamic of the system for charging mode of operation is shown in Figure 29. SOC increases until it reached 100% and the SOC permit block the converter to stop it from charging more.

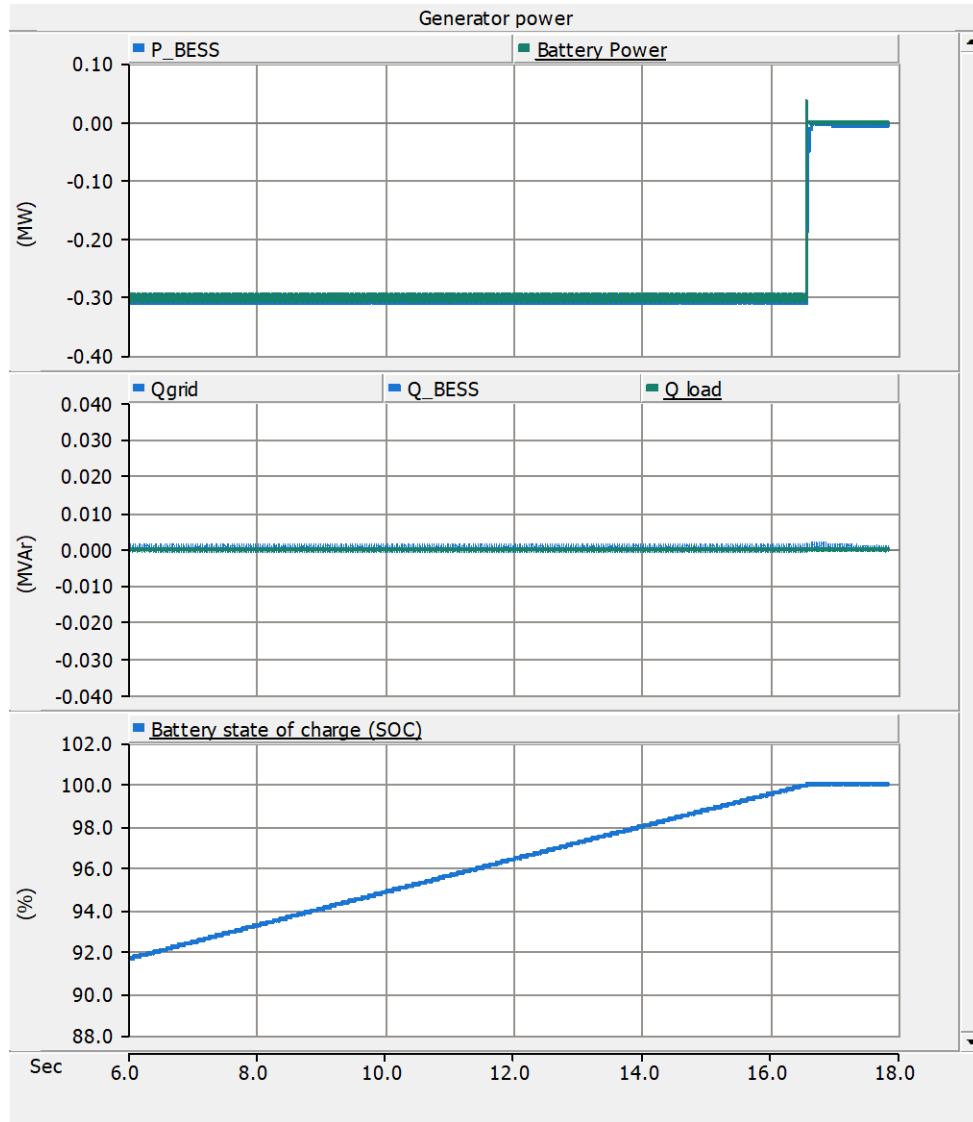

Figure 29: Simulation results of charging operation mode



### 5.3 Simulation results during a fault on the PCC:

The dynamic of the system during a fault on the point of common coupling (PCC) is shown in Figure 30. The converter is able to inject reactive power during a three-phase to ground fault and shows its fault ride through capability.

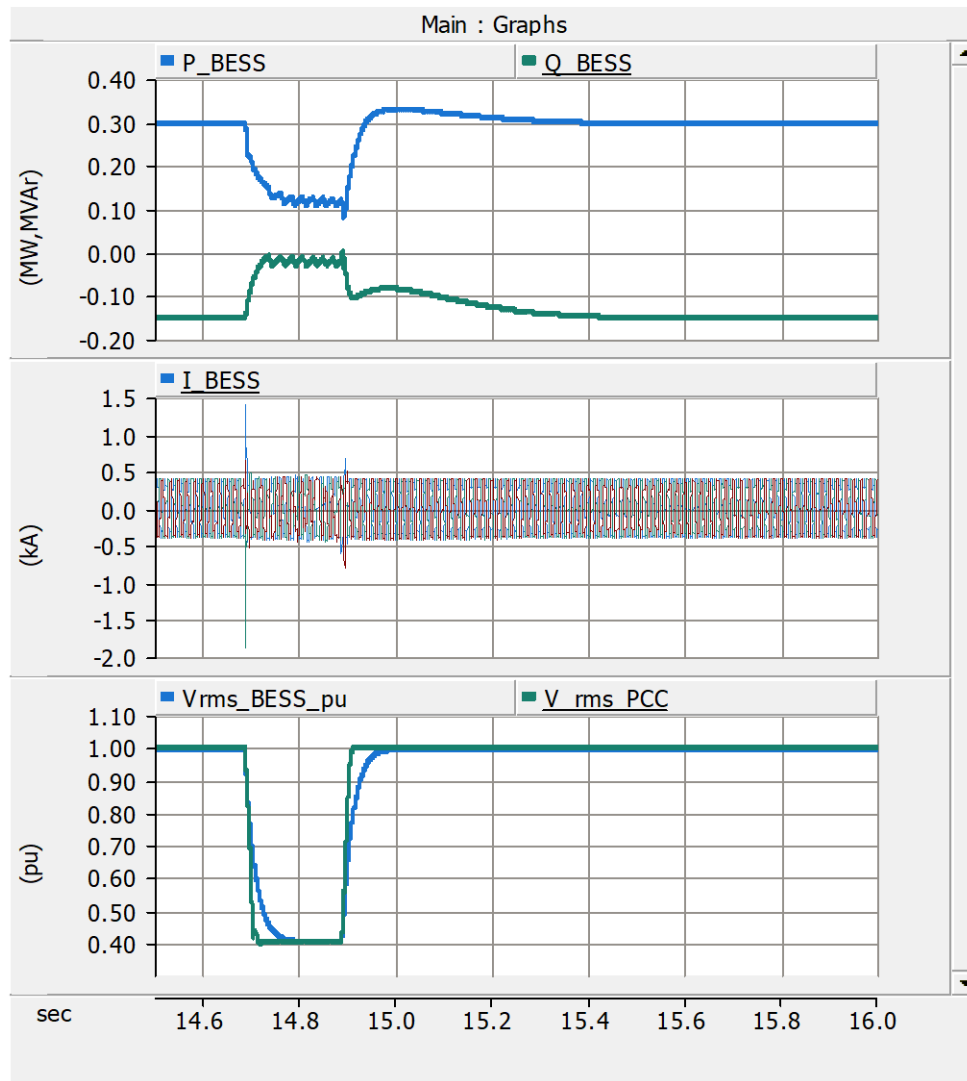

Figure 30: Fault ride through capability of BESS

#### Reference

- [1] Tremblay, O., Dessaint, L.-A., Dekkiche, A.-I., *A Generic Battery Model for the Dynamic Simulation of Hybrid Electric Vehicles*, Vehicle Power and Propulsion Conference, 2007, VPPC 2007, IEEE vol., no., pp.284-289, 9-12 Sept., 2007.